



MOBILIER
FURNITURE

KISS

LINE

Ed. 2

Sebastian Bergne for Pierre Frey



Collection ICÔNE



© Iona Wolff

KISS by Sebastian Bergne

Le designer britannique Sebastian Bergne est diplômé du Royal College of Art en 1990. Il fonde immédiatement son studio de création. Polyvalent, il est à la fois consultant en design industriel, éditeur, designer et fournisseur d'objets sur-mesure.

Il est réputé pour rendre les objets du quotidien, spéciaux, grâce notamment à son approche essentielle et humaine du design. Ses créations sont facilement identifiables dans leur évidence fonctionnelle et leur simplicité travaillée. Sebastian Bergne se plaît à décrire le design comme un processus à partir duquel tout peut être rendu beau, utile, significatif, approprié, ou tout simplement plaisant à utiliser.

Reconnu à travers le monde, son travail a été récompensé par de nombreux prix internationaux de design. Ses créations sont exposées dans les collections permanentes du Musée des Arts Décoratifs de Paris, au Museum of Modern Art de New York ou au Design Museum de Londres.

British designer Sebastian Bergne graduated from the Royal College of Art in 1990. He immediately founded his design studio. He is a multi-talented industrial design consultant, editor, designer and supplier of custom-made objects.

He is known for making everyday objects special, thanks to his essential and human approach to design. His creations are easily identifiable in their functional evidence and their worked simplicity. Sebastian Bergne likes to describe design as a process by which anything can be made beautiful, useful, meaningful, appropriate, or simply fun to use.

His work has been recognized worldwide and has won numerous international design awards. His creations are on exhibit in the permanent collections of the Musée des Arts Décoratifs in Paris, the Museum of Modern Art in New York and the Design Museum in London.

LE CONCEPT

La ligne KISS, aux volumes compacts et soigneusement proportionnés, questionne l'assise traditionnelle. L'agencement des formes défie la construction attendue d'un mobilier et notre rapport à l'objet. De généreux volumes tapissés se touchent à peine pour former des compositions délicatement équilibrées, sensuelles et fonctionnelles. La laque sublime la rigidité des surfaces extérieures et contraste avec un intérieur moelleux.

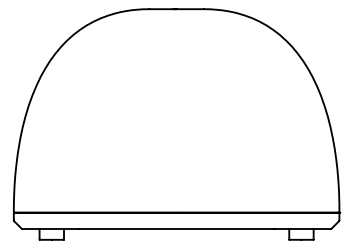
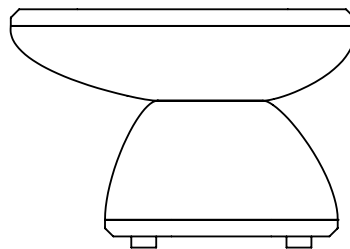
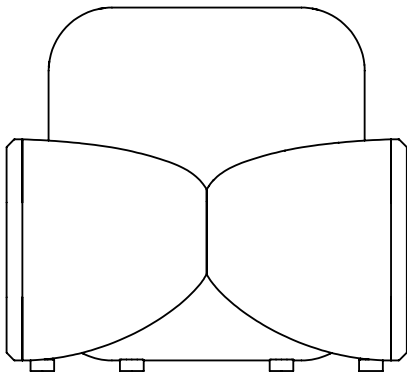

THE CONCEPT

The KISS line, with its compact and carefully proportioned volumes, puts into question traditional seating. The arrangement of shapes challenges the expected construction of furniture and our relationship to the object. Generous upholstered volumes barely touch each other to form delicately balanced compositions, sensual and functional. The lacquer refines the rigidity of the exterior surfaces and contrasts with a soft interior.

KISS

LINE



KISS
Chauffeuse - Slipper chair
FKISSCF072



KISS
Chauffeuse - Slipper chair
FKIS2CF072



KISS
Guéridon - Side table
FKISSGU063



KISS
Guéridon - Side table
FKIS2GU063



KISS
Repose-pieds - Ottoman
FKISSRE063



KISS
Repose-pieds - Ottoman
FKIS2RE063











KISS by Sebastian Bergne



Tissu / Fabric : BOLD Cigare F3212005
 Finition / Finish : Laque RAL 6022 vernis brillant / RAL 6022 glossy lacquer

FAUTEUIL - ARMCHAIR

REF: FKISSCF072

STRUCTURE	FRAME
Hêtre	Beech
Panneaux de dossier et panneaux latéraux laqués	Lacquered back and side panels
FINITIONS BOIS	WOOD FINISHES
Panneaux: Laque toutes références RAL	Panels: Lacquer all RAL references
Piètement en hêtre massif laqué	Lacquered solid beech feet
Disponible en finition mat, satiné, brillant	3 possible finishes: matte, satin or gloss
FINITIONS TAPISSIER	UPHOLSTERED FINISHES
Tissu tendu et coutures simples	Stretched fabric and simple seams
SPÉCIFICITÉ	SPECIFICITY
Se référer à la liste de tissus compatibles	Refer to suitable fabrics list
MÉTRAGE TISSU	FABRIC QUANTITY
3 m	3,5 yds
Métrage pour un tissu uni laize uni 140 cm	Quantity for a plain fabric in 55" width

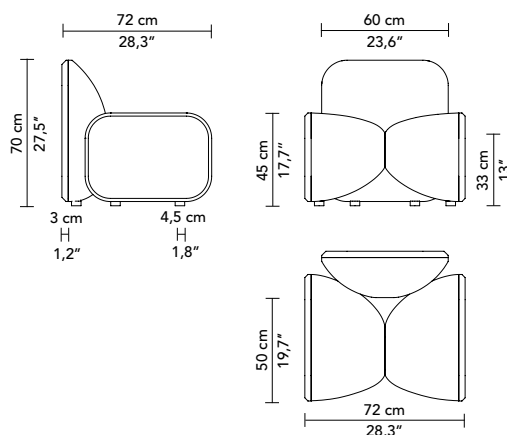

KISS by Sebastian Bergne



Tissu / Fabric : BOLD God Save The Queen F3212013
 Finition / Finish : Laque RAL 8007 vernis brillant / RAL 8007 glossy lacquer

GUÉRIDON - SIDE TABLE

REF: FKISSGU063

STRUCTURE	FRAME
Hêtre	Beech
Plateau et socle laqués	Lacquered top and base
FINITIONS BOIS	WOOD FINISHES
Panneaux: Laque toutes références RAL	Panels: Lacquer all RAL references
Piètement en hêtre massif laqué	Lacquered solid beech feet
Disponible en finition mat, satiné, brillant	3 possible finishes: matte, satin or gloss
FINITIONS TAPISSIER	UPHOLSTERED FINISHES
Tissu tendu et coutures simples	Stretched fabric and simple seams
SPÉCIFICITÉ	SPECIFICITY
Se référer à la liste de tissus compatibles	Refer to suitable fabrics list
MÉTRAGE TISSU	FABRIC QUANTITY
1,5 m	2 yds
Métrage pour un tissu uni laize uni 140 cm	Quantity for a plain fabric in 55" width

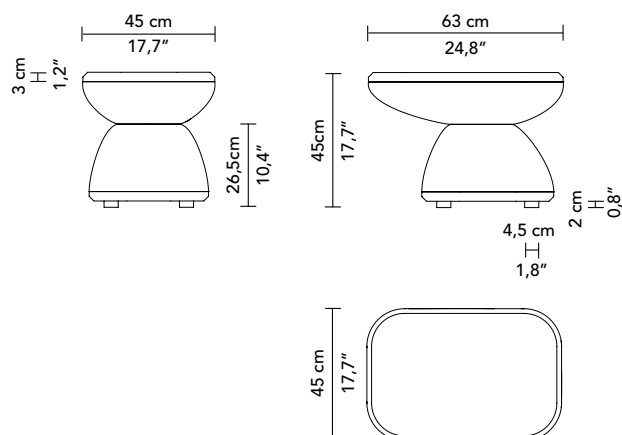





KISS by Sebastian Bergne



Tissu / Fabric : BOLD Cigare F3212005
 Finition / Finish : Laque RAL 6022 vernis brillant / RAL 6022 glossy lacquer

REPOSE-PIEDS - OTTOMAN

REF: FKISSRE063

STRUCTURE	FRAME
Hêtre	Beech
Socle laqué	Lacquered base
FINITIONS BOIS	WOOD FINISHES
Socle: Laque toutes références RAL	Base : Lacquer all RAL references
Piètement en hêtre massif laqué	Lacquered solid beech feet
Disponible en finition mat, satiné, brillant	3 possible finishes: matte, satin or gloss
FINITIONS TAPISSIER	UPHOLSTERED FINISHES
Tissu tendu et coutures simples	Stretched fabric and simple seams
SPÉCIFICITÉ	SPECIFICITY
Se référer à la liste de tissus compatibles	Refer to suitable fabrics list
MÉTRAGE TISSU	FABRIC QUANTITY
1,5 m	2 yds
Métrage pour un tissu uni laize uni 140 cm	Quantity for a plain fabric in 55" width

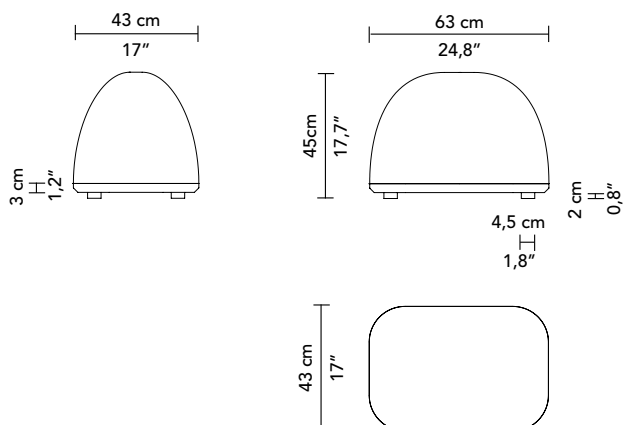







Tissu / Fabric : TEDDY MOHAIR Dune F2500029
Finition bois / Wood finish : Teinte châtaignier sur hêtre, vernis mat HB004M / Chestnut stain on beech, matt varnish HB004M







Tissu / Fabric : GIPSY Herbe F3608012
Finition bois / Wood finish : Teinte châtaignier sur hêtre, vernis mat HB004M / Chestnut stain on beech, matt varnish HB004M







Tissu / Fabric : BOLD Army F3212006
Finition bois / Wood finish : Laque RAL 3007 vernis brillant - RAL 3007 gloss lacquer







