



MOBILIER  
FURNITURE

# VÉNUS

LINE

Sam Baron for Pierre Frey



Collection HÉRITAGE

---





© Thinkers & Doers

# VÉNUS by Sam Baron

Né en France, Sam Baron est diplômé de l'école des beaux arts de Saint Etienne et possède un post diplôme de l'école nationale des Arts Décoratifs de Paris.

Sam Baron ancre ses créations dans les recherches fonctionnelles et artistiques sans omettre les narrations culturelles et historiques. Son regard se positionne dans notre quotidien et la vie contemporaine au travers de relectures et réinterprétations de savoir-faire artisanaux ou industriels.

En 2009 il reçoit le grand prix de la création de la ville de Paris dans la section designer confirmé et est désigné en 2010 par Philippe Starck comme l'un des designers les plus importants de la décennie.

Born in France, Sam Baron is a graduate of the Saint Etienne School of Fine Arts and has a post-graduate degree from l'école nationale des Arts Décoratifs de Paris.

Sam Baron anchors his creations in functional and artistic research without omitting cultural and historical narratives. His vision is positioned in our daily and contemporary life through rereadings and reinterpretations of artisanal or industrial know-how.

In 2009 he received the Grand Prix de la Création de la Ville de Paris in the confirmed designer section and in 2010 he was named by Philippe Starck as one of the most important designers of the decade.

## LE CONCEPT

La ligne VÉNUS, imaginée par Sam Baron, incarne un souffle nouveau dans l'univers du mobilier contemporain. Mariant habilement le classique et le moderne, son esthétique se distingue par une élégance affirmée. La corniche subtile ornant le piétement met en valeur la richesse et les nuances naturelles du bois.

Le plateau, disponible en finitions personnalisables, apporte une dimension précieuse à l'ensemble. Laques artistiques (Glacée, Kozo, Empreinte), chêne gougé ou verre laqué offrent des variations raffinées qui créent un dialogue harmonieux entre textures et matières, sublimant le design d'une originalité rare.

## THE CONCEPT

The VÉNUS line, conceived by Sam Baron, introduces a fresh perspective to contemporary furniture design. Seamlessly merging classical and modern influences, its aesthetic is defined by a confident elegance. The subtle cornice adorning the base accentuates the wood's richness and natural nuances.

The tabletop, offered in customizable finishes, infuses the VÉNUS collection with sophistication. Artistic lacquers such as Glacée, Kozo, and Empreinte, gouged oak, or lacquered glass provide refined variations that foster a harmonious dialogue between textures and materials, elevating the design with a rare and distinctive originality.

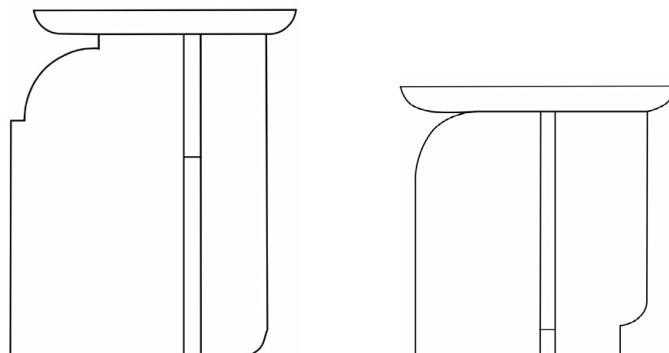

# V É N U S

## L I N E



### V É N U S

Guéridon - Pedestal table - 39 cm / 15,3 inch

FVENUGU039 - Structure chêne, plateau verre laqué / Oak structure, lacquered glass top

FVENUGU039BI1 - Structure chêne, insert chêne gougé / Oak structure, gouged oak insert

FVENUGU039BI2 - Structure chêne, insert laque Glacée / Oak structure, Icy lacquer insert

FVENUGU039BI3 - Structure chêne, insert laque Kozo / Oak structure, Kozo lacquer insert

FVENUGU039BI4 - Structure chêne, insert laque Empreinte / Oak structure, Stamp lacquer insert



### V É N U S

Guéridon - Pedestal table - 42 cm / 16,5 inch

FVENUGU042 - Structure chêne, plateau verre laqué / Oak structure, lacquered glass top

FVENUGU042BI1 - Structure chêne, insert chêne gougé / Oak structure, gouged oak insert

FVENUGU042BI2 - Structure chêne, insert laque Glacée / Oak structure, Icy lacquer insert

FVENUGU042BI3 - Structure chêne, insert laque Kozo / Oak structure, Kozo lacquer insert

FVENUGU042BI4 - Structure chêne, insert laque Empreinte / Oak structure, Stamp lacquer insert









# VÉNUS

by Sam Baron



Finition : Structure en teinte Blanchi sur chêne, vernis mat CO020M - Insert en Chêne gougé, Brun, vernis mat CO008GOM  
 Finish: Structure in Bleached stain on oak, matt varnish CO020M - Insert in matt varnished Brown gouged oak CO008GOM

## GUÉRIDON - PEDESTAL TABLE

REF: FVENUGU039BI1

| STRUCTURE  | FRAME   |                 |               |
|--|---|-----------------|---------------|
| Chêne massif                                     | Solid oak   |                 |               |
| Assemblage : traditionnel                        | Construction: traditional                           |                 |               |
| FINITIONS  | FINISHES  |                 |               |
| Chêne teinté, vernis à l'eau, insert chêne gougé | Stained oak, water-based varnish, gouged oak insert |                 |               |
| Existe avec inserts :                            | Available with inserts:                             |                 |               |
| - Laque Glacée                                   | FVENUGU039BI2                                       | - Icy lacquer   | FVENUGU039BI2 |
| - Laque Kozo                                     | FVENUGU039BI3                                       | - Kozo lacquer  | FVENUGU039BI3 |
| - Laque Empreinte                                | FVENUGU039BI4                                       | - Stamp lacquer | FVENUGU039BI4 |

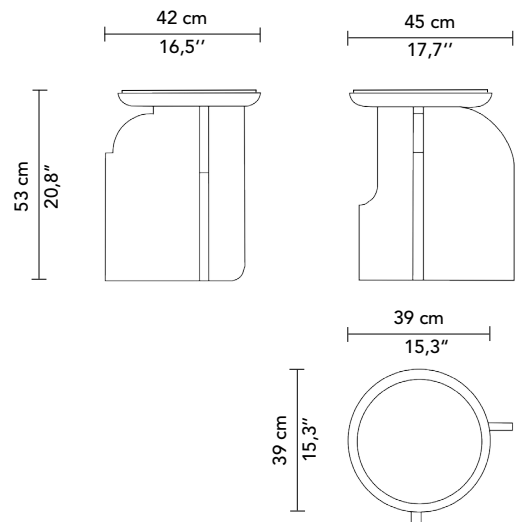





# VÉNUS

by Sam Baron



Finition : Structure en teinte Blanchi sur chêne, vernis mat CO020M - Insert en laque Glacée, Graphite, vernis satiné LG002S  
 Finish: Structure in Bleached stain on oak, matt varnish CO020M - Insert in satin varnished Graphite Icy Lacquer LG002S

## GUÉRIDON - PEDESTAL TABLE

REF: FVENUGU039B12

| STRUCTURE   | FRAME  |
|---|--|
| Chêne massif<br>Assemblage : traditionnel         | Solid oak<br>Construction: traditional               |
| FINITIONS   | FINISHES   |
| Chêne teinté, vernis à l'eau, insert laque Glacée | Stained oak, water-based varnish, Icy lacquer insert |
| Existe avec inserts :                             | Available with inserts:                              |
| - Chêne gougé FVENUGU039B11                       | - Gougé oak FVENUGU039B11                            |
| - Laque Kozo FVENUGU039B13                        | - Kozo lacquer FVENUGU039B13                         |
| - Laque Empreinte FVENUGU039B14                   | - Stamp lacquer FVENUGU039B14                        |

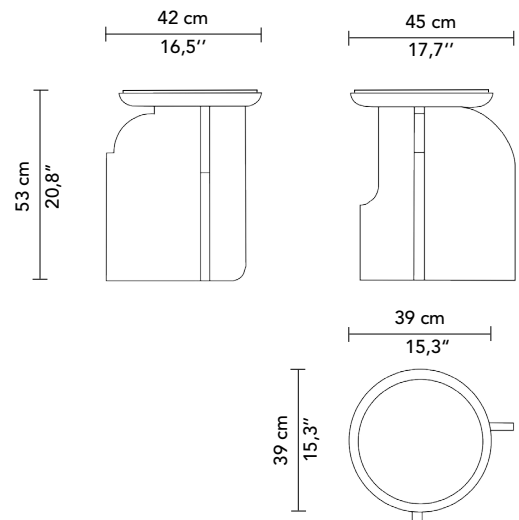

# VÉNUS

by Sam Baron



Finition : Structure en teinte Blanchi sur chêne, vernis mat CO020M - Insert en laque Kozo, Safran, vernis brillant LK001B  
 Finish: Structure in Bleached stain on oak, matt varnish CO020M - Insert in high gloss varnished Saffron Kozo lacquer LK001B

## GUÉRIDON - PEDESTAL TABLE

REF: FVENUGU039B13

| STRUCTURE                                       |               | FRAME   |               |
|---|---------------|---|---------------|
| Chêne massif                                    |               | Solid oak   |               |
| Assemblage : traditionnel                       |               | Construction: traditional                             |               |
| FINITIONS                                       |               | FINISHES  |               |
| Chêne teinté, vernis à l'eau, insert laque Kozo |               | Stained oak, water-based varnish, Kozo lacquer insert |               |
| Existe avec inserts :                           |               | Available with inserts:                               |               |
| - Chêne gougé                                   | FVENUGU039B11 | - Gougé oak   | FVENUGU039B11 |
| - Laque Glacée                                  | FVENUGU039B12 | - Icy lacquer   | FVENUGU039B12 |
| - Laque Empreinte                               | FVENUGU039B14 | - Stamp lacquer                                       | FVENUGU039B14 |

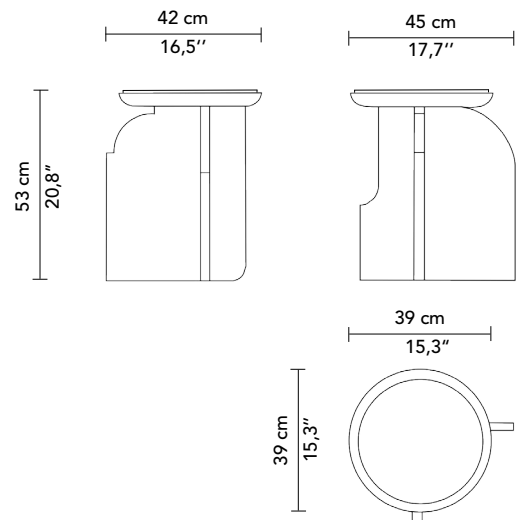

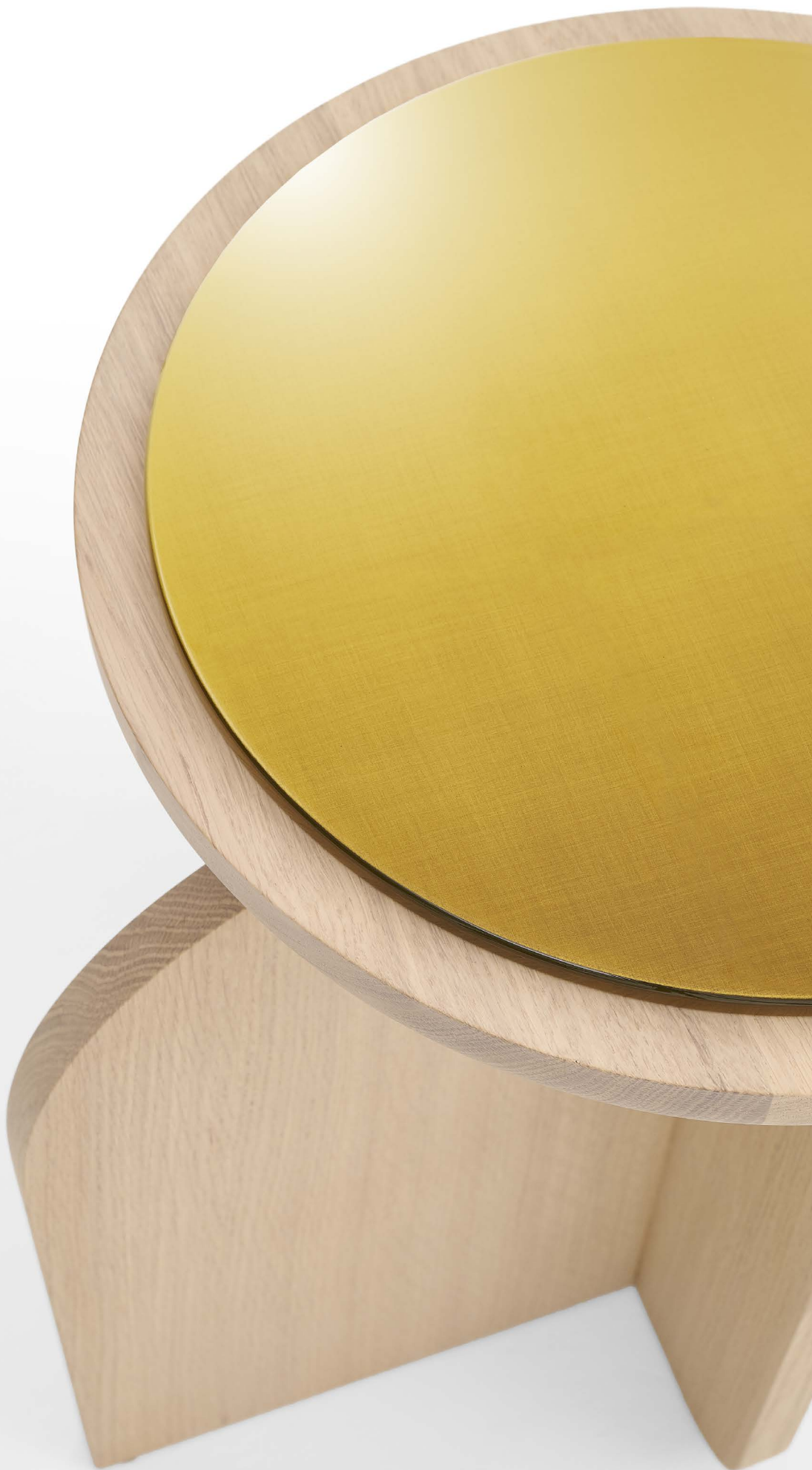



# VÉNUS

by Sam Baron



Finition : Structure en teinte Châtaignier sur chêne, vernis mat CO004M - Plateau en verre laqué  
 Finish: Structure in Chestnut stain on oak, matt varnish CO004M - Top in lacquered glass

## GUÉRIDON - PEDESTAL TABLE

REF: FVENUGU039

| STRUCTURE  | FRAME   |
|--|---|
| Chêne massif   | Solid oak   |
| Assemblage : traditionnel                            | Construction: traditional                             |
| FINITIONS  | FINISHES  |
| Chêne teinté, vernis à l'eau, plateau en verre laqué | Stained oak, water-based varnish, lacquered glass top |

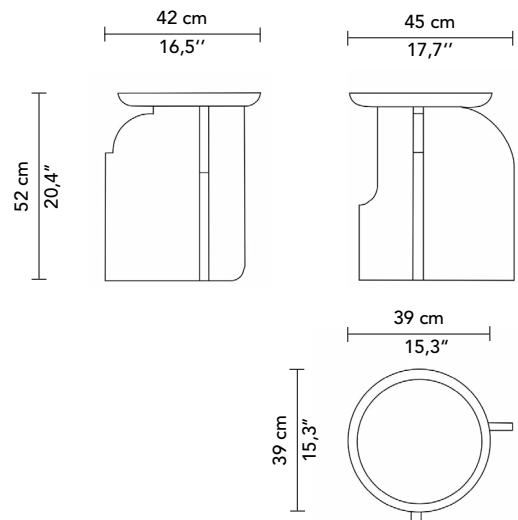

# VÉNUS

by Sam Baron



Finition : Structure en teinte Acajou sur chêne, vernis mat CO006M - Insert en Chêne gougé, Acajou, vernis mat CO006GOM  
 Finish: Structure in Mahogany stain on oak, matt varnish CO006M - Insert in matt varnished Mahogany gouged oak CO006GOM

## GUÉRIDON - PEDESTAL TABLE

REF: FVENUGU042B11

| STRUCTURE                 | FRAME                     |
|---------------------------|---------------------------|
| Chêne massif              | Solid oak                 |
| Assemblage : traditionnel | Construction: traditional |

| FINITIONS  | FINISHES  |
|--|---|
| Chêne teinté, vernis à l'eau, insert chêne gougé | Stained oak, water-based varnish, gouged oak insert |

| Existe avec inserts : |               | Available with inserts: |               |
|-----------------------|---------------|-------------------------|---------------|
| - Laque Glacée        | FVENUGU042B12 | - Icy lacquer           | FVENUGU042B12 |
| - Laque Kozo          | FVENUGU042B13 | - Kozo lacquer          | FVENUGU042B13 |
| - Laque Empreinte     | FVENUGU042B14 | - Stamp lacquer         | FVENUGU042B14 |





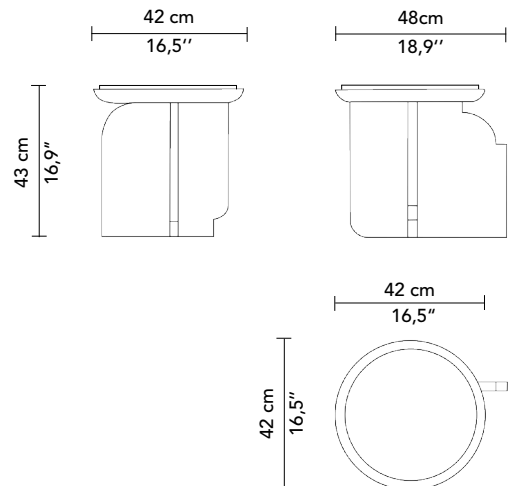

# VÉNUS

by Sam Baron



Finition : Structure en teinte Acajou sur chêne, vernis mat CO006M - Insert en laque Empreinte, Terracotta, vernis brillant LE001B  
 Finish: Structure in Mahogany stain on oak, matt varnish CO006M - Insert in high gloss varnished Terracotta Stamp lacquer LE001B

## GUÉRIDON - PEDESTAL TABLE

REF: FVENUGU042BI4

| STRUCTURE  | FRAME  |
|--|--|
| Chêne massif<br>Assemblage : traditionnel            | Solid oak<br>Construction: traditional                 |
| FINITIONS  | FINISHES   |
| Chêne teinté, vernis à l'eau, insert laque Empreinte | Stained oak, water-based varnish, Stamp lacquer insert |
| Existe avec inserts :                                | Available with inserts:                                |
| - Chêne gougé<br>- Laque Glacée<br>- Laque Kozo      | - Gougé oak<br>- Icy lacquer<br>- Kozo lacquer         |
| FVENUGU042BI1<br>FVENUGU042BI2<br>FVENUGU042BI3      | FVENUGU042BI1<br>FVENUGU042BI2<br>FVENUGU042BI3        |

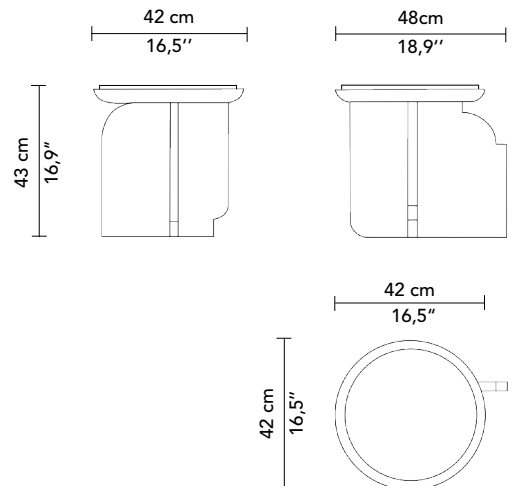

# VÉNUS

by Sam Baron



Finition : Structure en teinte Châtaignier sur chêne, vernis mat CO004M - Plateau en verre laqué  
 Finish: Structure in Chestnut stain on oak, matt varnish CO004M - Top in lacquered glass

## GUÉRIDON - PEDESTAL TABLE

REF: FVENUGU042

| STRUCTURE  | FRAME   |
|--|---|
| Chêne massif   | Solid oak   |
| Assemblage : traditionnel                            | Construction: traditional                             |
| FINITIONS  | FINISHES  |
| Chêne teinté, vernis à l'eau, plateau en verre laqué | Stained oak, water-based varnish, lacquered glass top |

