



MOBILIER
FURNITURE

VALLON

LINE

Christophe Delcourt for Pierre Frey



Collection SIGNATURE

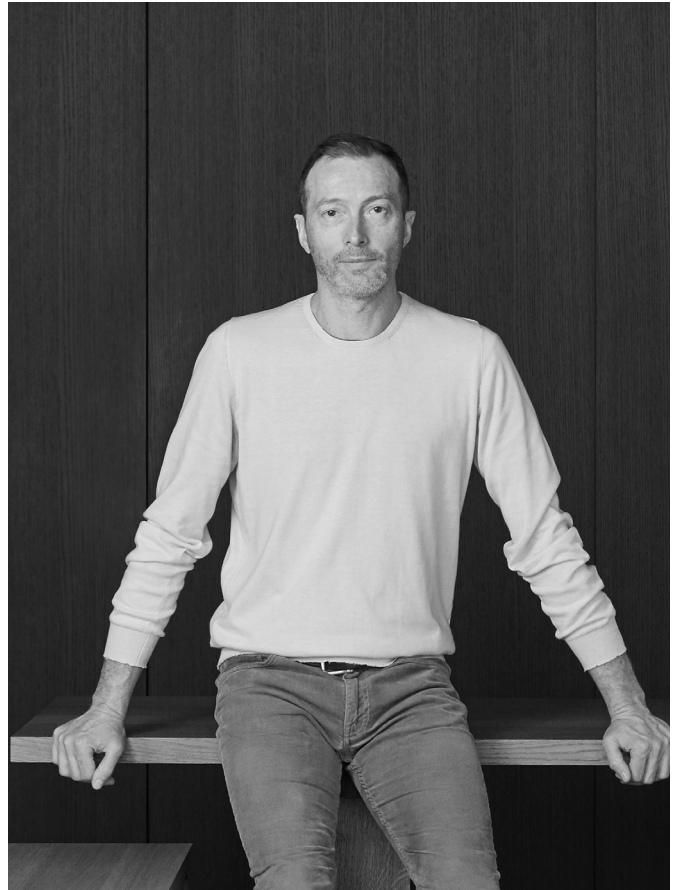

© Francis Amiard

VALLON by Christophe Delcourt

Christophe Delcourt est à la fois designer, éditeur et architecte d'intérieur.

Autodidacte, il apprend auprès d'artisans et adapte toujours son travail en fonction de l'atelier qui va le réaliser. Il dessine ainsi chacune de ses créations en respectant les contraintes techniques et en valorisant les gestes et les savoir-faire. Christophe Delcourt se définit lui-même comme un artisan. Sa matière de prédilection est le bois et il valorise la fabrication traditionnelle. Son ADN réside dans le sur-mesure reposant sur des savoir-faire haut de gamme et toujours plus perfectionnés. Il est sensible aux formes pures, aux lignes féminines, sensuelles ou sculpturales, inspirées par l'art.

Christophe Delcourt is a designer, publisher and interior architect.

Self-taught, he learns from craftsmen and always adapts his work according to the workshop that will realize it. He designs each of his creations while respecting the technical constraints and valuing the gestures and know-how. Christophe Delcourt defines himself as a craftsman. His favorite material is wood, he likes traditional manufacturing and the entire world of upholstery. His DNA lies in custom-made products based on high-end and ever more sophisticated know-how. He is sensitive to pure forms, feminine and sensual lines or sculptural inspired by art.

LE CONCEPT

La ligne VALLON offre une harmonie raffinée et un design à la sophistication discrète mais innovant. Chauffeuse et canapé s'inscrivent dans une intemporalité élégante aux formes sensuelles et aux courbes audacieuses. VALLON se distingue par son double bombé et un passepoil qui relie également le dossier et l'assise, créant une silhouette fluide visible sous tous les angles.

Le design sculptural et accueillant incarne un savoir-faire luxueux, repoussant les limites de l'artisanat classique pour proposer une esthétique qui traverse les époques. Chaque pièce est conçue avec une structure en bois travaillé dans les règles de l'art et un rembourrage en mousse multicouche offrant un confort exceptionnel.

En collaboration avec la Maison Pierre Frey, Christophe Delcourt élargit les horizons des lignes de Pierre Frey Mobilier. Cette synergie met en lumière la recherche mutuelle d'un équilibre sensible entre une allure moderne et un design hors du temps.

THE CONCEPT

The VALLON line offers refined harmony and a design of understated yet innovative sophistication. Its slipperchair and sofa embody timeless elegance with sensual shapes and bold curves. VALLON is distinguished by its double curvature and piping that also connects the backrest and seat, creating a fluid silhouette visible from every angle.

The sculptural and inviting design embodies luxurious craftsmanship, pushing the boundaries of classical craftsmanship to offer an aesthetic that transcends time. Each piece is crafted with a meticulously worked wooden structure and multi-layer foam padding for exceptional comfort.

In collaboration with Maison Pierre Frey, Christophe Delcourt expands the horizons of Pierre Frey Furniture's lines. This synergy highlights their mutual pursuit of a sensitive balance between modern allure and timeless design.

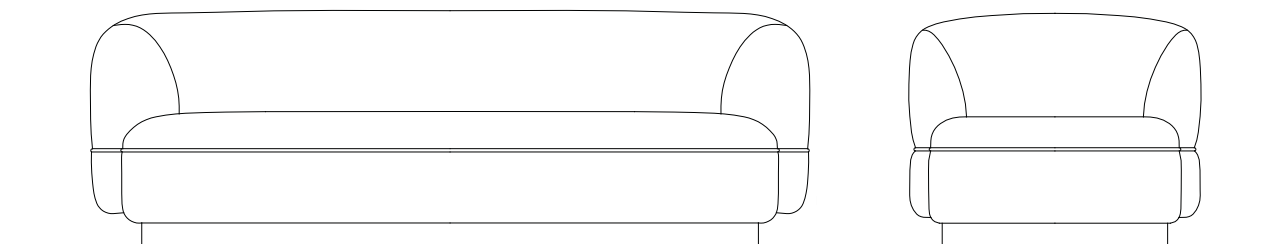

VALLON

LINE



VALLON - 220 cm
Canapé - Sofa

FVALLCA220 - Socle tapissé / Upholstered base
FVALLCA220B2 - Socle chêne / Oak base



VALLON - 240 cm
Canapé - Sofa

FVALLCA240 - Socle tapissé / Upholstered base
FVALLCA240B2 - Socle chêne / Oak base



VALLON
Chaufeuse - Slipper chair

FVALLCF095 - Socle tapissé / Upholstered base
FVALLCF095B2 - Socle chêne / Oak base
FVALLCF095W - Pivotant / Swivel













VALLON

by Christophe Delcourt



Tissu / Fabric : TEDDY MOHAIR Hérisson F2500028

CANAPÉ - SOFA

REF: FVALLCA220

STRUCTURE	FRAME
Hêtre	Beech
FINITIONS	FINISHES
Socle tapissé : FVALLCA220	Fully upholstered: FVALLCA220
Socle chêne : FVALLCA220B2	Oak base: FVALLCA220B2
SPÉCIFICITÉ	SPECIFICITY
Se référer à la liste de tissus compatibles	Refer to suitable fabrics list
Tissus utilisés en contresens	Fabrics used on the bias (the fabrics are not cut on the straight grain)
MÉTRAGE TISSU	FABRIC QUANTITY
9 m	9,5 yds
Métrage pour un tissu uni en laize 140 cm	Quantity for a plain fabric in 55" width

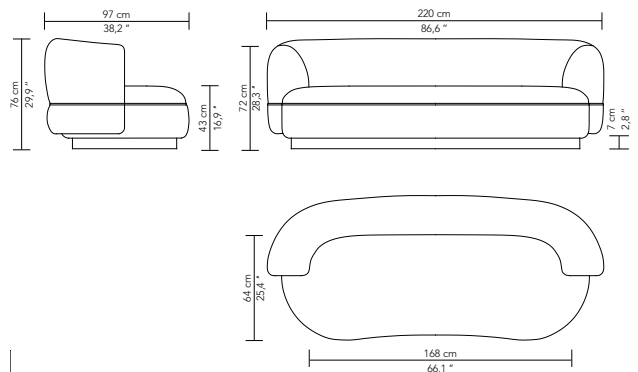





VALLON

by Christophe Delcourt



Tissu / Fabric : TOUNDRA Ambre F3928004
 Finition / Finish : Teinte Acajou sur chêne, vernis mat CO006M / Mahogany satin on oak, matt varnish CO006M

CANAPÉ - SOFA

REF: FVALLCA240B2

STRUCTURE	FRAME
Hêtre	Beech
FINITIONS	FINISHES
Socle tapissé : FVALLCA240	Fully upholstered: FVALLCA240
Socle chêne : FVALLCA240B2	Oak base: FVALLCA240B2
SPÉCIFICITÉ	SPECIFICITY
Se référer à la liste de tissus compatibles	Refer to suitable fabrics list
Tissus utilisés en contresens	Fabrics used on the bias (the fabrics are not cut on the straight grain)
MÉTRAGE TISSU	FABRIC QUANTITY
9 m	10 yds
Métrage pour un tissu uni en laize 140 cm	Quantity for a plain fabric in 55" width

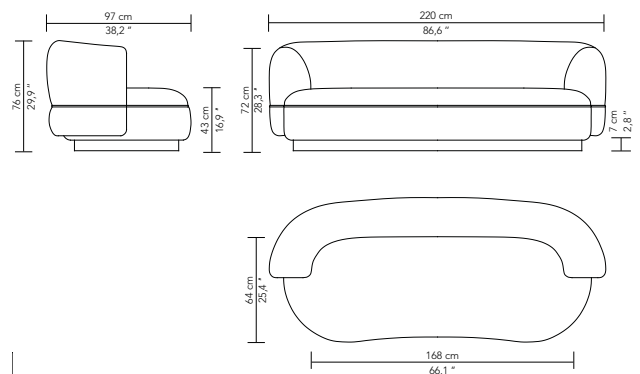

VALLON

by Christophe Delcourt



Tissu / Fabric : SAINT BRIAC Ambre F3936020

CHAUFFEUSE - SLIPPER CHAIR

REF: FVALLCF095

STRUCTURE	FRAME
Hêtre	Beech
FINITIONS	FINISHES
Socle tapissé : FVALLCF095 Socle chêne : FVALLCF095B2	Fully upholstered: FVALLCF095 Oak base: FVALLCF095B2
SPÉCIFICITÉ	SPECIFICITY
Se référer à la liste de tissus compatibles Existe également en version pivotante :	Refer to suitable fabrics list Also available in a swivel version:
FVALLCF095W	FVALLCF095W
MÉTRAGE TISSU	FABRIC QUANTITY
5 m Métrage pour un tissu uni en laize 140 cm	5,5 yds Quantity for a plain fabric in 55" width

