



MOBILIER
FURNITURE

NATALIE

LIGNE - LINE

Zanellato/Bortotto for Pierre Frey





NATALIE

Zanellato/Bortotto

Giorgia Zanellato et Daniele Bortotto ont créé leur agence en 2013 à Trévise après leurs diplômes à l'université IUAV de Venise et un master de design produit à l'ECAL en Suisse. Giorgia fait un passage par Fabrica, centre de recherche en design, pendant que Daniele collabore avec le designer suisse Adrien Rovero. Ils présentent leur premier projet commun, Acqua Alta, au Salone Satellite de Milan la même année et démarrent leurs recherches sur le rapport entre les lieux et le temps qui passe à travers la réinterprétation de techniques artisanales traditionnelles.

A la fois designers produits et directeurs artistiques de projets de décoration, le duo collabore avec des entreprises italiennes et internationales. Leur travail est exposé dans plusieurs galeries et institutions telles que le MAXXI de Rome, le musée du design de la Triennale, le musée Poldi Pezzoli de Milan, la Sommerset House et la galerie Aram de Londres. En 2015, ils sont nommés jeunes talents de l'année par Elle Décor Italie et remportent de nombreux prix pour leurs différents travaux.

Giorgia Zanellato and Daniele Bortotto founded their agency in 2013 in Treviso after graduating from IUAV University in Venice and completing a master's degree in product design at ECAL in Switzerland. Giorgia does a passage through Fabrica, a design research center, while Daniele collaborates with Swiss designer Adrien Rovero. They presented their first joint project, Acqua Alta, at the Salone Satellite in Milan the same year and began their research on the relationship between place and time through the reinterpretation of traditional craft techniques.

Both product designers and artistic directors of decoration projects, the duo collaborates with Italian and international companies. Their work is exhibited in several galleries and institutions such as MAXXI in Rome, the Triennale Design Museum, the Poldi Pezzoli Museum in Milan, Sommerset House and the Aram Gallery in London. In 2015 they were named young talent of the year by Elle Décor Italy and won numerous awards for their various works.

LE CONCEPT

La ligne NATALIE est né de la fascination du duo italien Zanellato et Bortoto pour l'atmosphère des anciens salons culturels parisiens. Le nom Natalie fait écho à Natalie Clifford Barney, une femme de lettres américaine du XXème siècle connue pour son salon littéraire et artistique dédiée aux femmes rue Jacob, à Paris dans l'Entre Deux Guerres. Natalie retraduit, au sein de ses courbes généreuses, un statut de pièce de décorateur. Une structure au design épuré challenge subtilement les codes classiques et contraste avec les volumes doux et accueillants de l'assise tapissée.

THE CONCEPT

The NATALIE line was inspired by the Italian duo Zanellato and Bortoto's fascination with the atmosphere of old Parisian cultural salons. The name Natalie echoes Natalie Clifford Barney, an American woman of letters of the 20th century known for her literary and artistic salon dedicated to women on rue Jacob, in Paris during the interwar period. Natalie retraces, within its generous curves, a decorator's piece status. A pure design structure subtly challenges classical codes and contrasts with the soft and welcoming volumes of the upholstered seat.

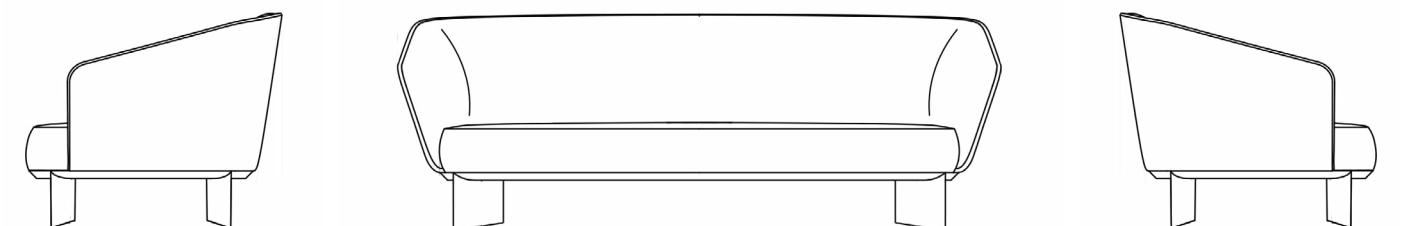

NATALIE LIGNE - LINE



NATALIE
Canapé - Sofa
FNATACA225



NATALIE
Fauteuil - Armchair
FNATAFA112



NATALIE
Table
FNATATA100



NATALIE
Table
FNAT1TA100



NATALIE
Guéridon - Pedestal table
FNATAGU037



NATALIE
Guéridon - Pedestal table
FNAT1GU037







Tissu / Fabric : FAUVE L5054CV_C510_C512_E













Tissu / Fabric : IGOR Caramel F3635008





















Tissu / Fabric : PYLA ORGE F3637014









FICHE TECHNIQUE / TECHNICAL SHEET



Tissu / Fabric : SWANN Neige F3491001

NATALIE

CANAPE - SOFA

REF: FNATACA225

STRUCTURE	FRAME
Chêne massif et panneau de bois Assemblage : Traditionnel	Solid oak and wood panel Construction: Traditional
CONFORT	COMFORT
Châssis plein Structure : Mousse Polyuréthane 40/40 parementée de ouate polyester Assise : Mousse HR (Haute Résilience) 35kg/m3, mousse HR 35/10kg/m3, parmentée de ouate polyester Dossier : Mousse HR (Haute Résilience) 26kg/m3, mousse HR 35/10kg/m3, parmentée de ouate polyester	Solid seat Structure : Polyurethane foam 40/40 wrapped in polyester wadding Seat : HR foam (High Resilience) 35kg/m3, HR foam 35/10kg/m3, wrapped with polyester wadding Back : HR foam (High Resilience) 26kg/m3, HR foam 35/10kg/m3, covered with polyester wadding
FINITION BOIS	WOOD FINISH
Chêne teinté, vernis à l'eau	Stained oak, water-based varnish
FINITIONS TAPISSIER	UPHOLSTERED FINISHES
Coutures simples et coutures rabattues	Single and folded seams
EN OPTION	OPTIONAL
2 Coussins en plumes d'oies 85X53 cm	2 Goose feather cushions 33,5" x 20,9"
PIÈCES COORDONNÉES	COORDINATED PIECES
Canapé, Fauteuil, Table, Guéridon	Sofa, Armchair, Table, Pedestal table

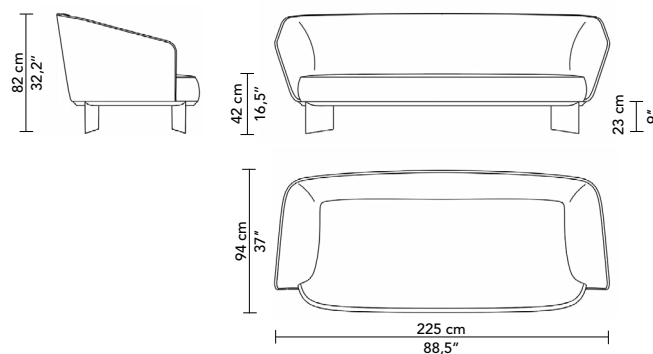

MÉTRAGE TISSU

- FNATACA225 : 8 m

FABRIC QUANTITY

- FNATACA225 : 9 yds

Poids : 80 kg

Weight : 176,37 lbs

Eco participation obligatoire pour une livraison
en France : 9,6 € HT



FICHE TECHNIQUE / TECHNICAL SHEET



Tissu / Fabric : PYLA Orge F3637014

NATALIE

FAUTEUIL - ARMCHAIR

REF: FNATAFA112

STRUCTURE	FRAME
Chêne massif et panneau de bois Assemblage : Traditionnel	Solid oak and wood panel Construction: Traditional
CONFORT	COMFORT
Châssis plein Structure : Mousse Polyuréthane 40/40 parementée de ouate polyester Assise : Mousse HR (Haute Résilience) 35kg/m3, mousse HR 35/10kg/m3, parmentée de ouate polyester Dossier : Mousse HR (Haute Résilience) 26kg/m3, mousse HR 35/10kg/m3, parmentée de ouate polyester	Solid seat Structure : Polyurethane foam 40/40 wrapped in polyester wadding Seat : HR foam (High Resilience) 35kg/m3, HR foam 35/10kg/m3, wrapped with polyester wadding Back : HR foam (High Resilience) 26kg/m3, HR foam 35/10kg/m3, covered with polyester wadding
FINITION BOIS	WOOD FINISH
Chêne teinté, vernis à l'eau	Stained oak, water-based varnish
FINITIONS TAPISSIER	UPHOLSTERED FINISHES
Coutures simples et coutures rabattues	Single and folded seams
PIÈCES COORDONNÉES	COORDINATED PIECES
Canapé, Fauteuil, Table, Guéridon	Sofa, Armchair, Table, Pedestal table

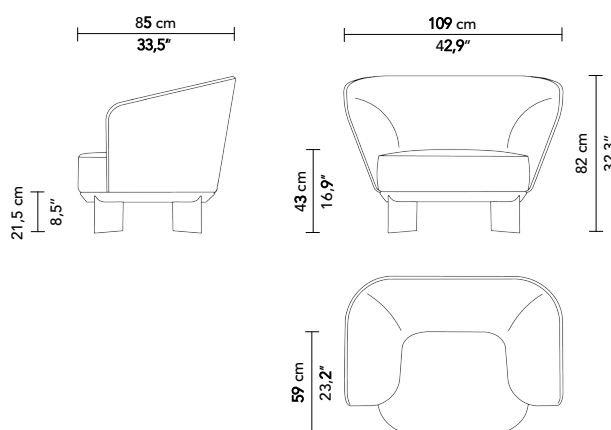

MÉTRAGE TISSU

- FNATAFA112 : 4 m

FABRIC QUANTITY

- FNATAFA112 : 4,5 yds

Poids : 40 kg

Weight : 88,2 lbs

Eco participation obligatoire pour une livraison
en France : 4,80 € HT



FICHE TECHNIQUE / TECHNICAL SHEET



NATALIE

TABLE

REF: FNATATA100

STRUCTURE	FRAME
Chêne massif et panneau de bois Assemblage : Traditionnel	Solid oak and wood panel Construction: Traditional
FINITION BOIS	WOOD FINISH
Chêne teinté, vernis à l'eau	Stained oak, water-based varnish
OPTION	OPTIONAL
Plateau en marbre FNAT1TA100	Marble top FNAT1TA100
PIÈCES COORDONNÉES	COORDINATED PIECES
Canapé, Fauteuil, Table, Guéridon	Sofa, Armchair, Table, Pedestal table

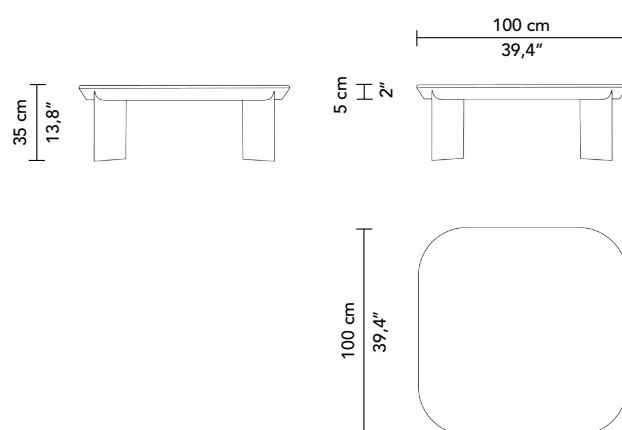

Poids : 35 kg

Weight : 77,2 lbs

Eco participation obligatoire pour une livraison
en France : 4,20 € HT



FICHE TECHNIQUE / TECHNICAL SHEET



NATALIE

TABLE

REF: FNAT1TA100

STRUCTURE	FRAME
Chêne massif et panneau de bois	Solid oak and wood panel
Plateau en marbre blanc de Carrare	Carrara white marble top
Assemblage : Traditionnel	Construction: Traditional
FINITION BOIS	WOOD FINISH
Chêne teinté, vernis à l'eau	Stained oak, water-based varnish
OPTION	OPTIONAL
Plateau en bois FNATATA100	Wooden top FNATATA100
PIÈCES COORDONNÉES	COORDINATED PIECES
Canapé, Fauteuil, Table, Guéridon	Sofa, Armchair, Table, Pedestal table

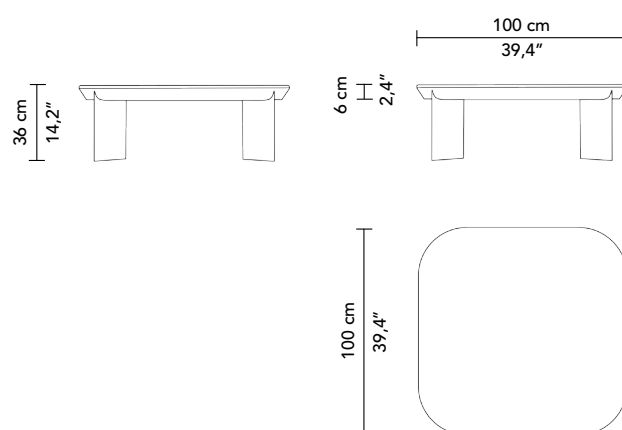

Poids : 64 kg

Weight : 141 lbs

Eco participation obligatoire pour une livraison
en France : 7,68 € HT



FICHE TECHNIQUE / TECHNICAL SHEET



NATALIE

GUERIDON - PEDESTAL TABLE

REF: FNATAGU037

STRUCTURE	FRAME
Chêne massif et panneau de bois Assemblage : Traditionnel	Solid oak and wood panel Construction: Traditional
FINITION BOIS	WOOD FINISH
Chêne teinté, vernis à l'eau	Stained oak, water-based varnish
OPTION	OPTIONAL
Plateau en marbre FNAT1GU037	Marble top FNAT1GU037
PIÈCES COORDONNÉES	COORDINATED PIECES
Canapé, Fauteuil, Table, Guéridon	Sofa, Armchair, Table, Pedestal table

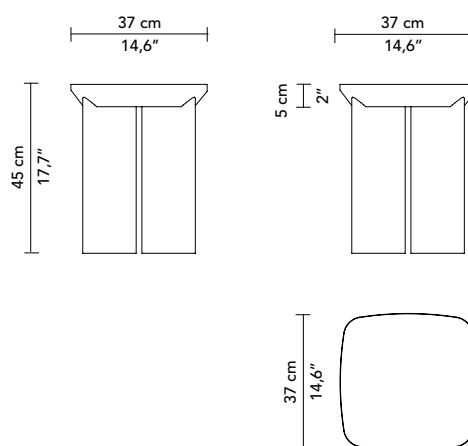

Poids : 13,5 kg

Weight : 29,8 lbs

Eco participation obligatoire pour une livraison
en France : 1,62 € HT



FICHE TECHNIQUE / TECHNICAL SHEET



NATALIE

GUERIDON - PEDESTAL TABLE

REF: FNAT1GU037

STRUCTURE	FRAME
Chêne massif et panneau de bois	Solid oak and wood panel
Plateau en marbre blanc de Carrare	Carrara white marble top
Assemblage : Traditionnel	Construction: Traditional
FINITION BOIS	WOOD FINISH
Chêne teinté, vernis à l'eau	Stained oak, water-based varnish
OPTION	OPTIONAL
Plateau en bois FNATAGU037	Wooden top FNATAGU037
PIÈCES COORDONNÉES	COORDINATED PIECES
Canapé, Fauteuil, Table, Guéridon	Sofa, Armchair, Table, Pedestal table

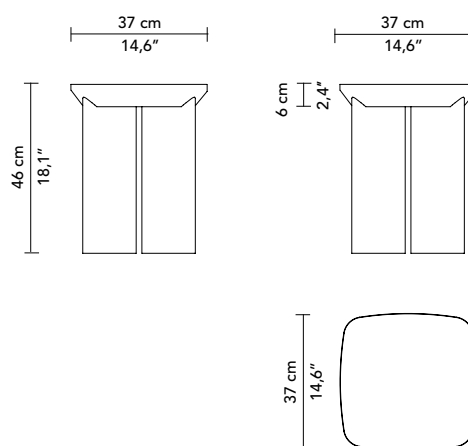

Poids : 17 kg

Weight : 37,5 lbs

Eco participation obligatoire pour une livraison
en France : 2,04 € HT

