



MOBILIER
FURNITURE

BUENOS AIRES

LINE

Ed. 2



Collection SIGNATURE

LE CONCEPT

La ligne BUENOS AIRES met à l'honneur la forme courbe dans un design sobre et contemporain. Le dossier enveloppant offre une expérience confortable. Sa forme accueillante donne envie de s'y lover. La finition passepoil souligne avec élégance les rondeurs des assises. Déclinée en fauteuil, méridienne et canapés, cette ligne à la personnalité assumée s'intègre facilement dans les intérieurs classiques et contemporains.

THE CONCEPT

The BUENOS AIRES line features a curved shape in a clean, contemporary design. The enveloping backrest offers a comfortable experience. Its welcoming shape makes you want to curl up. The piping finish elegantly highlights the curves of the seats. Available as an armchair, chaise longue and sofa, this line with its strong personality can easily be integrated into classic and contemporary interiors.

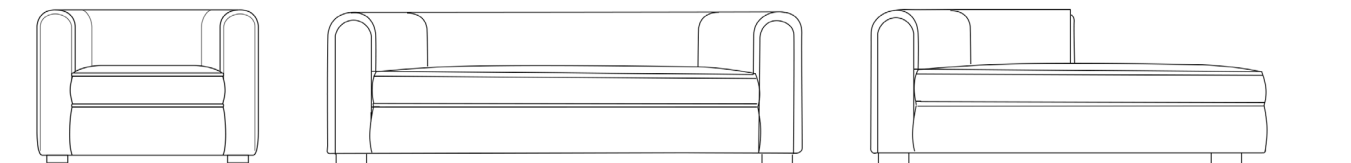

BUENOS AIRES

LINE



BUENOS AIRES
Fauteuil - Armchair
FBUEENFA090



BUENOS AIRES
Canapé - Sofa
FBUEENCA145



BUENOS AIRES
Canapé - Sofa
FBUEENCA170



BUENOS AIRES
Canapé - Sofa
FBUEENCA200

BUENOS AIRES

LINE



BUENOS AIRES
Canapé courbe - Curved sofa
FBUENCC245



BUENOS AIRES
Mériidienne - Chaise Lounge
FBUENME170H



BUENOS AIRES
Mériidienne - Chaise Lounge
FBUENME170D









BUENOS AIRES



Tissu / Fabric : TEDDY MOHAIR Dune F2500029
 Finition / Finish : Teinte Acajou sur hêtre, vernis mat HB006M / Mahogany stain on beech, matt varnish HB006M

FAUTEUIL - ARMCHAIR

REF: FBUENFA090

| | |
|---|--|
| STRUCTURE | FRAME |
| Hêtre et peuplier Assemblage : traditionnel avec tenons et mortaises | Beech and poplar Construction: tenon joints and mortises |
| FINITIONS PIÈTEMENT | WOOD FINISHES |
| Hêtre teinté vernis à l'eau, vissé | Water-based stained varnished beech, screwed |
| FINITIONS TAPISSIER | UPHOLSTERED FINISHES |
| Tissu tendu, couture simple et passepoil | Stretched fabric with single needle stitching and piping |
| SPÉCIFICITÉ | SPECIFICITY |
| Tissus utilisés en contresens Existe également en version pivotante : FBUENFA090W | Fabrics used on the bias (the fabrics are not cut on the straight grain) Also available in a swivel version: FBUENFA090W |
| MÉTRAGE TISSU | FABRIC QUANTITY |
| 4 m Métrage pour un tissu uni en laize 140 cm | 4,5 yds Quantity for a plain fabric in 55" width |

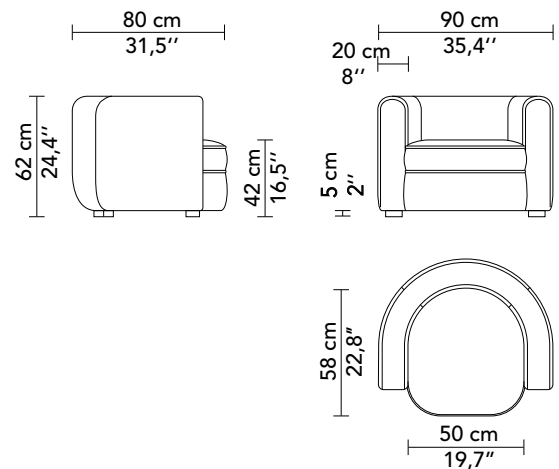





BUENOS AIRES



Tissu / Fabric : TEDDY MOHAIR Acajou F2500013
 Finition / Finish : Teinte Wengé sur hêtre, vernis mat HB007M / Wenge stain on beech, matt varnish HB007M

CANAPÉ - SOFA

REF: FBUENCA145

| STRUCTURE | FRAME |
|---|--|
| Hêtre et peuplier Assemblage : traditionnel avec tenons et mortaises | Beech and poplar Construction: tenon joints and mortises |
| FINITIONS PIÈTEMENT | WOOD FINISHES |
| Hêtre teinté vernis à l'eau, vissé | Water-based stained varnished beech, screwed |
| FINITIONS TAPISSIER | UPHOLSTERED FINISHES |
| Tissu tendu, couture simple et passepoil | Stretched fabric with single needle stitching and piping |
| SPÉCIFICITÉ | SPECIFICITY |
| Tissus utilisés en contresens | Fabrics used on the bias (the fabrics are not cut on the straight grain) |
| MÉTRAGE TISSU | FABRIC QUANTITY |
| 5 m Métrage pour un tissu uni en laize 140 cm | 5,5 yds Quantity for a plain fabric in 55" width |

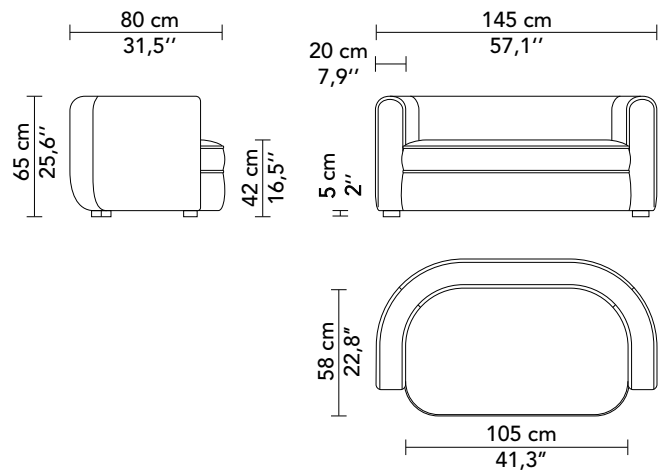

BUENOS AIRES



Tissu / Fabric : CHENILLE DE TOURS UNIE L4289
 Finition / Finish : Teintre Naturel sur hêtre, vernis mat HB000M / Natural stain on beech, matt varnish HB000M

CANAPÉ - SOFA

REF: FBUENCA170

| | |
|--|--|
| STRUCTURE | FRAME |
| Hêtre et peuplier | Beech and poplar |
| Assemblage : traditionnel avec tenons et mortaises | Construction: tenon joints and mortises |
| FINITIONS PIÈTEMENT | WOOD FINISHES |
| Hêtre teinté vernis à l'eau, vissé | Water-based stained varnished beech, screwed |
| FINITIONS TAPISSIER | UPHOLSTERED FINISHES |
| Tissu tendu, couture simple et passepoil | Stretched fabric with single needle stitching and piping |
| SPÉCIFICITÉ | SPECIFICITY |
| Tissus utilisés en contresens | Fabrics used on the bias (the fabrics are not cut on the straight grain) |
| MÉTRAGE TISSU | FABRIC QUANTITY |
| 6 m | 7 yds |
| Métrage pour un tissu uni en laize 140 cm | Quantity for a plain fabric in 55" width |

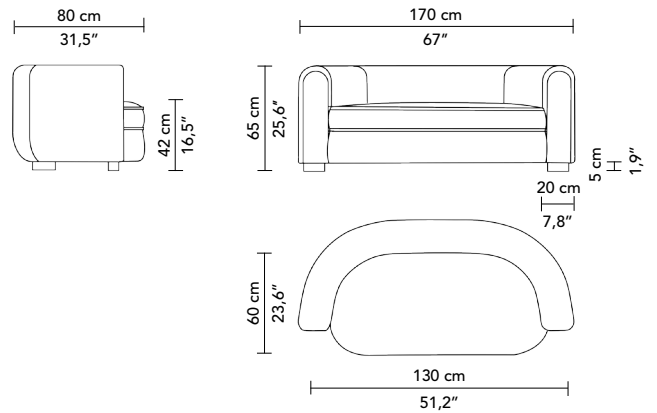





BUENOS AIRES



Tissu / Fabric : CHENILLE IGOR Sable F3635004
 Finition / Finish : Teinte Brun sur hêtre, vernis mat HB008M / Brown stain on beech, matt varnish HB008M

CANAPÉ - SOFA

REF: FBUENCA200

| | |
|---|--|
| STRUCTURE | FRAME |
| Hêtre et peuplier Assemblage : traditionnel avec tenons et mortaises | Beech and poplar Construction: tenon joints and mortises |
| FINITIONS PIÈTEMENT | WOOD FINISHES |
| Hêtre teinté vernis à l'eau, vissé | Water-based stained varnished beech, screwed |
| FINITIONS TAPISSIER | UPHOLSTERED FINISHES |
| Tissu tendu, couture simple et passepoil | Stretched fabric with single needle stitching and piping |
| SPÉCIFICITÉ | SPECIFICITY |
| Tissus utilisés en contresens | Fabrics used on the bias (the fabrics are not cut on the straight grain) |
| MÉTRAGE TISSU | FABRIC QUANTITY |
| 6,5 m Métrage pour un tissu uni en laize 140 cm | 7,5 yds Quantity for a plain fabric in 55" width |

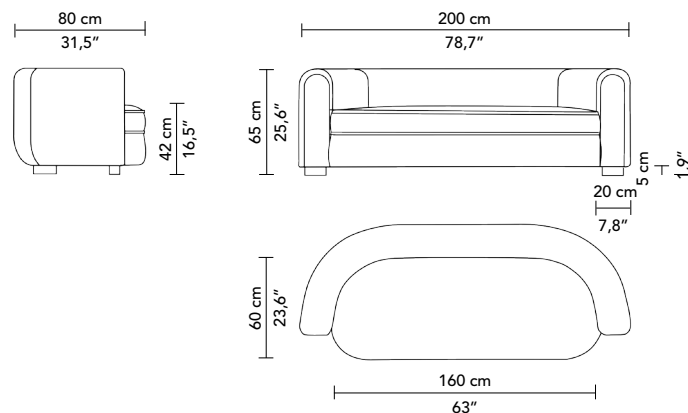

BUENOS AIRES



Tissu / Fabric : TEDDY MOHAIR Crème F2500002
 Finition / Finish : Teinte Miel sur hêtre, vernis mat HB001M / Honey stain on beech, matt varnish HB001M

CANAPÉ COURBE - CURVED SOFA

REF: FBUENCC245

| STRUCTURE | FRAME |
|---|--|
| Hêtre et peuplier Assemblage : traditionnel avec tenons et mortaises | Beech and poplar Construction: tenon joints and mortises |
| FINITIONS PIÈTEMENT | WOOD FINISHES |
| Hêtre teinté vernis à l'eau, vissé | Water-based stained varnished beech, screwed |
| FINITIONS TAPISSIER | UPHOLSTERED FINISHES |
| Tissu tendu, couture simple et passepoil | Stretched fabric with single needle stitching and piping |
| SPÉCIFICITÉ | SPECIFICITY |
| Tissus utilisés en contresens Largeur laize minimum : 135 cm | Fabrics used on the bias (the fabrics are not cut on the straight grain) Minimum fabric width: 53,15" |
| MÉTRAGE TISSU | FABRIC QUANTITY |
| 9,5 m Métrage pour un tissu uni en laize 140 cm | 10,5 yds Quantity for a plain fabric in 55" width |

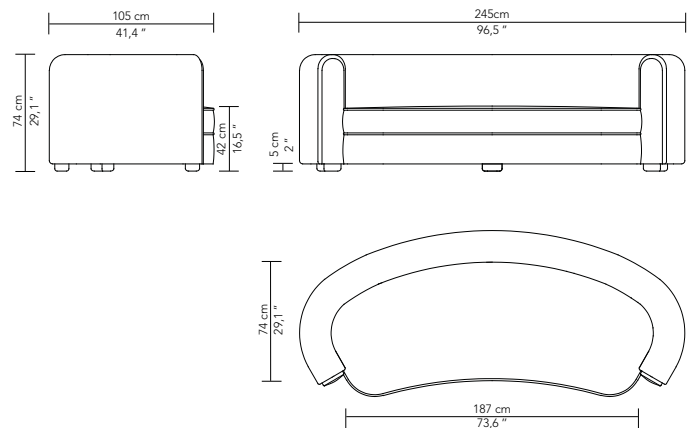





BUENOS AIRES



Tissu / Fabric : CHENILLE IGOR Olive F3635019
 Finition / Finish : Brun - Brown Finition / Finish : Teinte Brun sur hêtre, vernis mat HB008M / Brown stain on beech, matt varnish HB008M

MÉRIDIENNE - CHAISE LONGUE

REF: FBUEM170H

| STRUCTURE | FRAME |
|--|--|
| Hêtre et peuplier | Beech and poplar |
| Assemblage : traditionnel avec tenons et mortaises | Construction: tenon joints and mortises |
| FINITIONS PIÈTEMENT | WOOD FINISHES |
| Hêtre teinté vernis à l'eau, vissé | Water-based stained varnished beech, screwed |
| FINITIONS TAPISSIER | UPHOLSTERED FINISHES |
| Tissu tendu, couture simple et passepoil | Stretched fabric with single needle stitching and piping |
| SPÉCIFICITÉ | SPECIFICITY |
| Tissus utilisés en contresens | Fabrics used on the bias (the fabrics are not cut on the straight grain) |
| MÉTRAGE TISSU | FABRIC QUANTITY |
| 6 m | 7 yds |
| Métrage pour un tissu uni en laize 140 cm | Quantity for a plain fabric in 55" width |

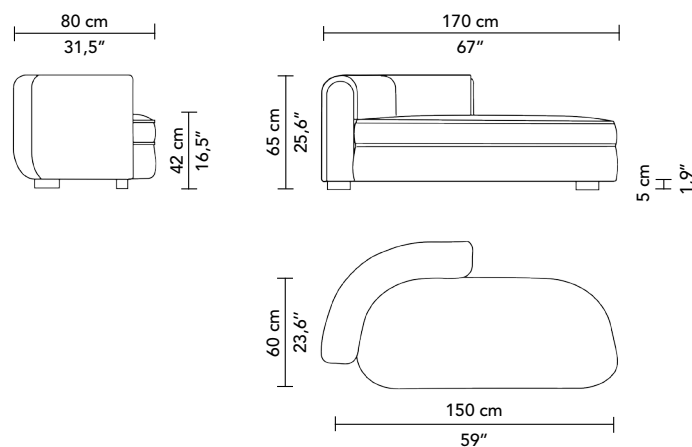

BUENOS AIRES



Tissu / Fabric : CHENILLE IGOR Olive F3635019
 Finition / Finish : Teinte Brun sur hêtre, vernis mat HB008M / Brown stain on beech, matt varnish HB008M

MÉRIDIENNE - CHAISE LONGUE

REF: FBUEM170D

| | |
|---|--|
| STRUCTURE | FRAME |
| Hêtre et peuplier Assemblage : traditionnel avec tenons et mortaises | Beech and poplar Construction: tenon joints and mortises |
| FINITIONS PIÈTEMENT | WOOD FINISHES |
| Hêtre teinté vernis à l'eau, vissé | Water-based stained varnished beech, screwed |
| FINITIONS TAPISSIER | UPHOLSTERED FINISHES |
| Tissu tendu, couture simple et passepoil | Stretched fabric with single needle stitching and piping |
| SPÉCIFICITÉ | SPECIFICITY |
| Tissus utilisés en contresens | Fabrics used on the bias (the fabrics are not cut on the straight grain) |
| MÉTRAGE TISSU | FABRIC QUANTITY |
| 6 m Métrage pour un tissu uni en laize 140 cm | 7 yds Quantity for a plain fabric in 55" width |

